

ALL IN ONE

**Heat Pump Water Heater**

**INSTALLATION AND OPERATION INSTRUCTIONS**

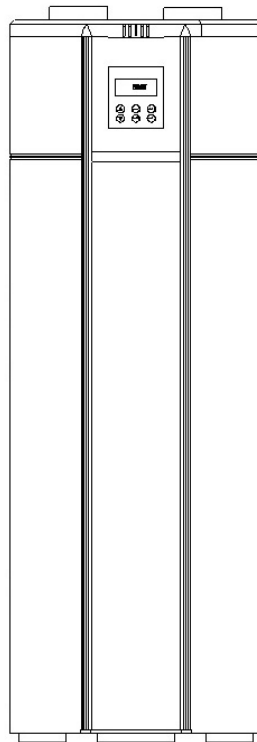

Please read this user's manual carefully before operate the unit.

# CONTENTS

A. IMPORTANT REMARKS -----	1
B. DESCRIPTION OF HEAT PUMP -----	2
C. INSTALLATION INSTRUCTION-----	3-5
D. OPERATION PANEL INSTRUCTION-----	6-9
E. MAINTENANCE AND SERVICE -----	10-11
F. UNIT CIRCUIT DIAGRAM-----	12-13
G. ANNEX LIST -----	14

## WARNING:

- 1. This unit must be installed by the professional persons, dealers or special installation companies authorized. Or otherwise, accidents maybe possibly caused and use effect maybe possibly be affected.*
- 2. Be sure that the unit is STOP operation when disconnecting the power supply to the unit .Disconnect all electric power supplies before servicing.*
- 3. This appliance is not intended for use by persons (including children) with reduced physical, or lack of experience and knowledge, unless they have been given supervision or instruction concerning use of the appliance by a person responsible for their safety.*
- 4. Children should be supervised to ensure that they do not play with the appliance.*
- 5. If the supply cord is damaged, it must be replaced by the manufacturer or its service agent or a similarly qualified person in order to avoid a hazard.*

## A. Important remarks

---

- *Thank you for choosing our products. Before installation, it is strongly recommended to read this instruction firstly. This manual includes the information of installation, debugging, running and maintenance of the products.*
- *Every unit of products has passed strictly test to ensure safety and high efficiency operation.*
- *The manufacturer of this product will not be held responsible if someone is injured or the unit is damaged, as a result of improper installation, debugging, and unnecessary maintenance which is not in line with this manual.*
- *The installer should be an authorized technician, and install the system follow the diagram on the equipment.*

### **Please notice the following information during installation:**

1. Applied working temperature of heat pump: -7~43°C.
2. Check whether the power supply and wire meet the standard of the unit.
3. Do not alter the power wire or socket and the metal parts should be connected to GND well. Do not change the GND connection of the system.
4. The appliance shall be installed in accordance with national wiring regulations.
5. When the system is connected to a fixed power supply, a 3mm space switch should be equipped. At the same time, must connect a power leakage protector. (30mA, 0.1sec.)
6. When finish all the wiring, check it again before power on.
7. Do not install the system in the warehouse where flammable gas may leak out.
8. Do not insert hands or object into the vent of the heat pump, it may cause the dangerous to people or damage the system.
9. To make the system more efficiency, please install the main unit at a place with good ventilation.
10. Do not put (or install) the operating panel at a wet place, do not cut and reconnect the connecting wire.
11. Before turn on the system at a first time, ensure the water tank is full filled with water.
12. The inlet of the water tank equips with a filter (detachable), clean it according to the water quality and running condition of the system (the period should be 2~3 months)
13. While the water supply has been stopped or the system stops running for a long period in winter, should be drain the tank water to avoid water system frost crack.
14. The highest temperature of outing water is 60°C, when using, tune up to a suitable temperature (the most suitable temperature for human is 38~45°C, if the temperature is higher than 55°C, it may cause the danger of scald). Normally, the setting temperature can be from 10°C - 60°C, the model with Auxiliary heater can reach up to 70°C.
15. Move the main unit at max. 30 degree angle. Do not drop down or upend the unit.
16. Maintain the system by an authorized technician. And disconnect all power when servicing.
17. Please provide the warrantee card and S/N No. enclosed with the product for after service.

## B. Description of heat pump

### Unit constructions (outside):

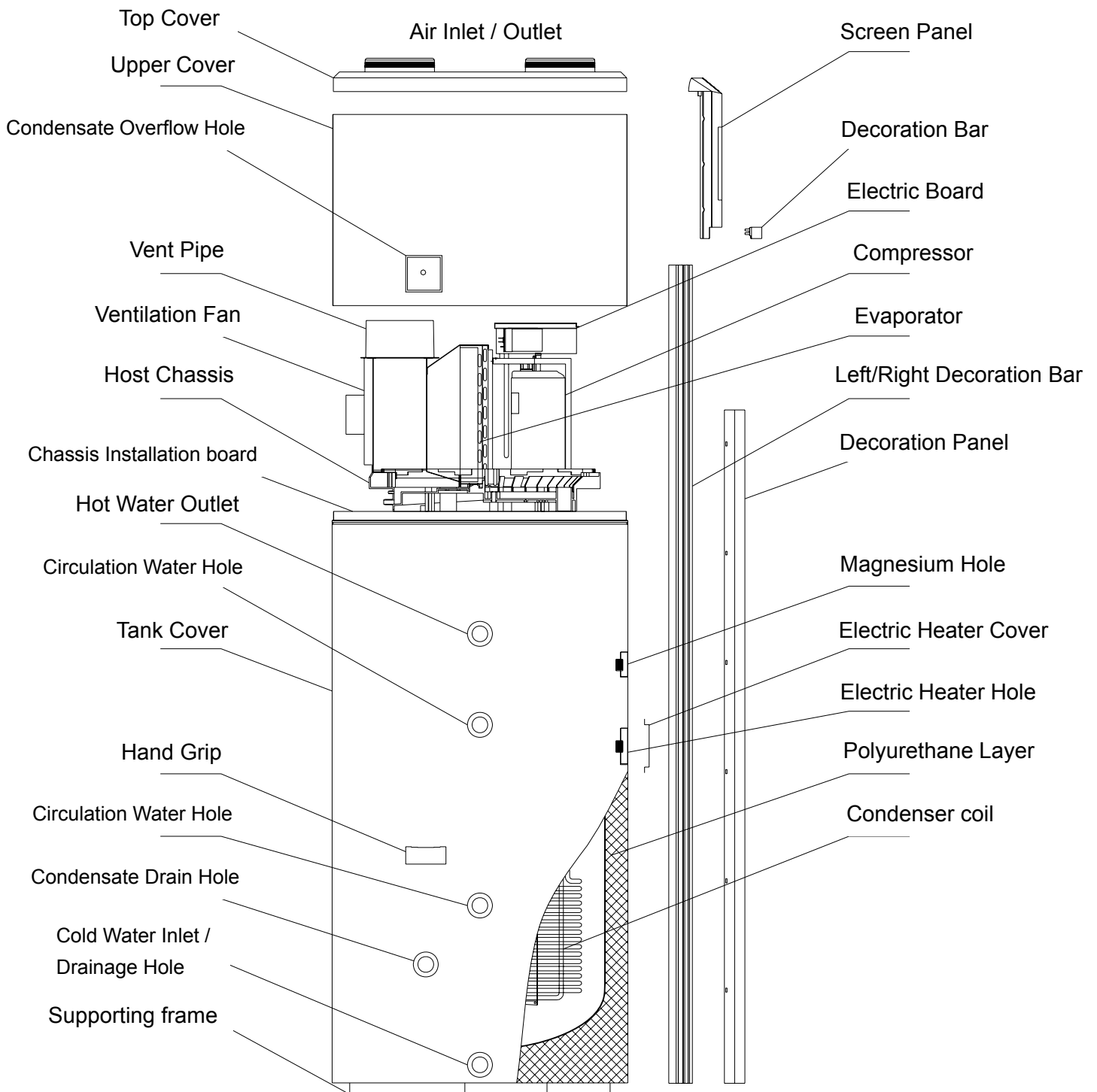

#### **Remark:**

1. The above drawing is for reference to identify the name of each part. Details are subject to real unit.
2. The drawing of "Electric Heater hole" is only for the unit with Auxiliary heater models; other models without auxiliary heater function are not available.
3. There are two "Circulation Water Hole" for optional connection. It can be available when the user requests an external connection for hot water circulation. Normal models are without these holes.

### C. Installation instruction

**Note:**

1. This heat pump unit can be installed at veranda, hallway or other place where is easy to install and stable. The air inlet and outlet are at the top side, main unit should not be placed at an open air. Avoid the rain or debris to enter the vents. The air inlet and outlet can connect the  $\phi 150\text{mm}$  air duct. As below,

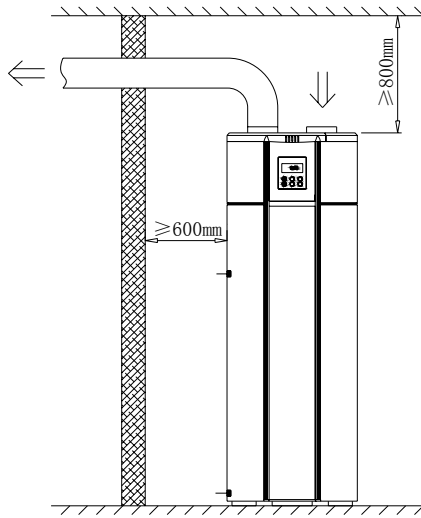

(Fig.1)

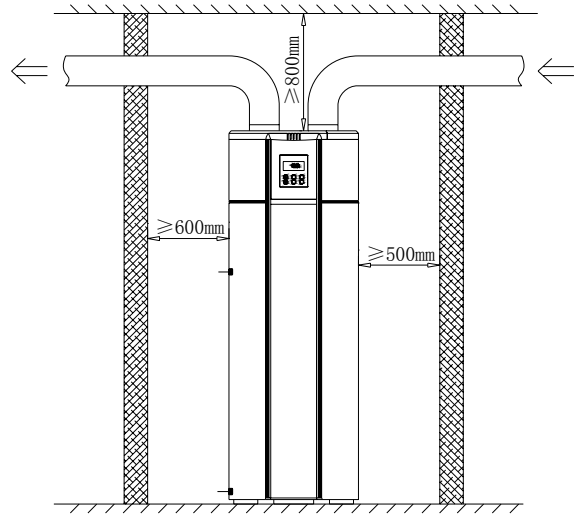

(Fig.2)

2. When install as Fig.1, only connect the air inlet or outlet, the unit should be installed at a place of ventilation, and the side connected with water pipes should has enough space. Then, if the unit is installed besides the room, it can be connected the air outlet duct to the room for exchange fresh air and cooling function; If the unit is installed in the room, it can be pulled out room's air for ventilation function.
3. If install as Fig. 2, the unit can be installed by the middle of the wall, and connect the air inlet and outlet pipe for air exchange. The distance of the unit and wall or other obstacle should not be too short. Keep a certain distance.
4. If install as Fig. 3, the unit is installed outside the room, the air inlet and outlet is connected indoor for air exchange (and cooling). In this way, the indoor air inlet and outlet should have a distance  $\geq 2\text{m}$  to avoid mix air.
5. Because the air outlet comes with cooling air, the surface of the pipe may have condensation water, it's necessary to insulate the indoor outlet pipe to prevent water leakage.
6. Heat pump water heater unit must be placed upright, and installed on a solid place where can be able to withstand the weight over 700kgs. Supporting surface should be evenness (obliquity less than  $2^\circ$  )
7. When install the unit, there should has some measures of sound insulation and shockproof in order not to affect neighbors.

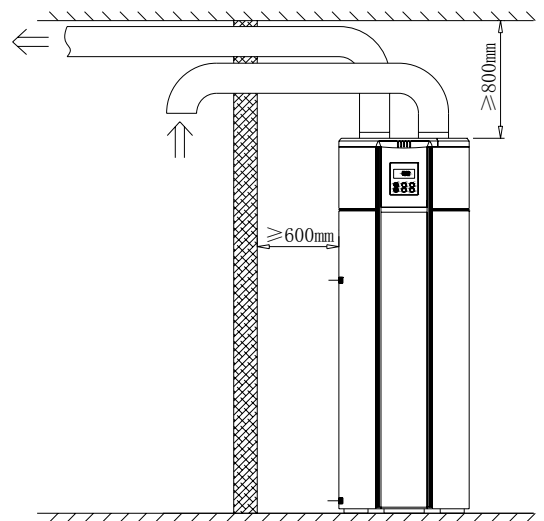

(Fig. 3)

## C. Installation instruction

---

8. When unit operation, put the unit in a well-ventilated place and non-blocking the air vent, so that the machine can be able to inhale and exhaust enough air, to achieve hot water supply function.
  9. There should be with drain around the system unit for drainage. And the surrounding should have enough space for maintenance. Because the top cover can be opened, at the top side of the unit should have  $\geq 800\text{mm}$  space for maintain.
  10. Nearby the system unit, there should be reserved a water supply pipe and hot water pipe interface equipped with valves, the water inlet pipe should be with filter (for cleaning).
  11. For waterway connection of this integrated unit, please refer to the following (Fig.4) "Waterway installation diagram". On the system unit, there should be installed Three-port valve, Safety valve and Filter. Connect them to the water inlet and outlet of the unit.
  12. If the Heat pump equip with "**Circulation Water Hole**" (optional), It can be connected with SOLAR WATER HEATER, HEAT RECOVERY SYSTEM and other water heating equipment to heat the water tank by circulation. Retain original if no need external connection.
  13. The working pressure of this water heater tank must  $\leq 0.7\text{MPa}$ . Water inlet must connect the safety valve, and its operation pressure is  $0.7\text{MPa}$ , Connect another end of the safety valve to water supply pipe. The safety valve should be connected by a small rubber pipe interlinked with atmosphere; this pipe must not be blocked, in order to drain the water when the tank's pressure exceeds  $0.7\text{MPa}$ .
  14. Water inlet pressure should  $> 0.1\text{MPa}$ , if the pressure is lower, can connect the pressure pump on inlet pipe to get the high water flow.
  15. Ensure the water tank is full fill with water before turn on the system: First, open the valve on the water supply inlet, then switch on either valve of the water outlet, and then you can affuse water to the tank until the water overflow the water outlet valve. After which you can turn off the water outlet valve and check for leakage. Make sure there is no water leaking.
- NOTE: For the first time use, ensure the water tank has been filled with water before turn on the system.***
16. In order to ensure the water tank filled with water, require a certain section of hot water outlet side should be about 10cm higher than the water heater tank section.
  17. The water heater temperature thermal sensor was put and sealed well in a tank by the factory before launch to market. No need to install it when installation.
  18. This water heater unit is filled with refrigerant by the factory, and no need to vacuumize or refill refrigerant.
  19. In the winter cold regions, the water heater unit can not turn off the power, if the system stops running for a long period in winter, should be drain the tank water to avoid water pipe or tank frost crack. Meanwhile, we should strengthen or check the external pipe to prevent the pipe frozen.

## C. Installation instruction

---

### Installation diagram:

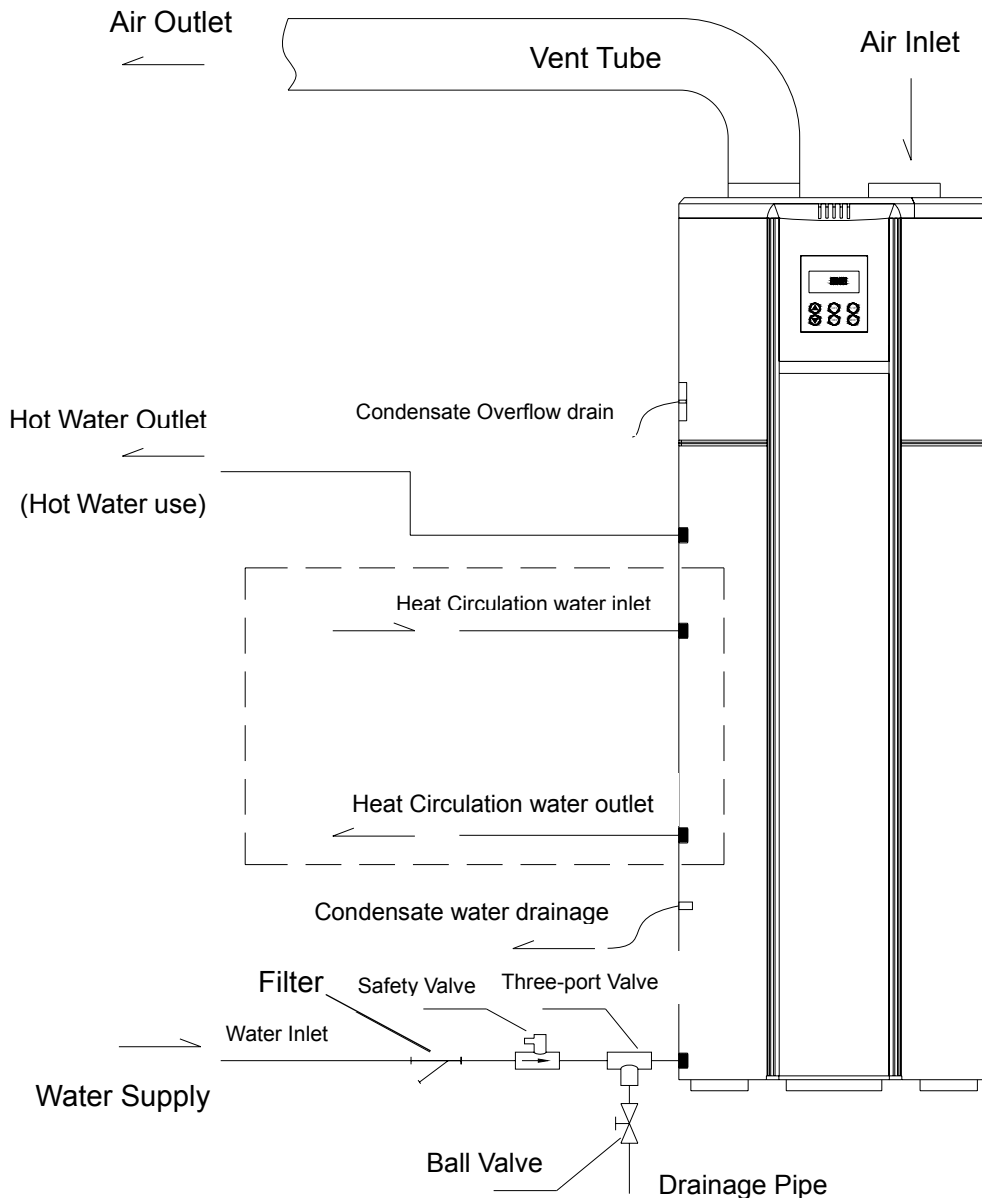

(Fig.4)

#### **Remark:**

1. For the first time use, ensure the water tank have been filled with water before power on to prevent burn out.
2. Follow with the water heater unit, there are some installation parts (see the annex detail list of parts). As for other water system components, the user or installation company should provide by themselves.
3. Before installation, it's better to reserve a water supply pipe interface, hot water outlet pipe interface and drainage pipe interface. Among them, the water supply pipe and hot water outlet pipe should be used in line with standards for drinking water pipes. (E.g. PPR pipe or stainless steel pipe, etc.), can not use iron pipe or the rubber hose with odor for installation.
4. If the using place below 0 °C, make sure to insulate the water pipes to prevent frozen.
5. Air inlet /outlet can connect  $\Phi 150\text{mm}$  vent tube, but pipe should not be too long and less crankle.

## D. Operation panel instruction

### 1. Panel - Operation:

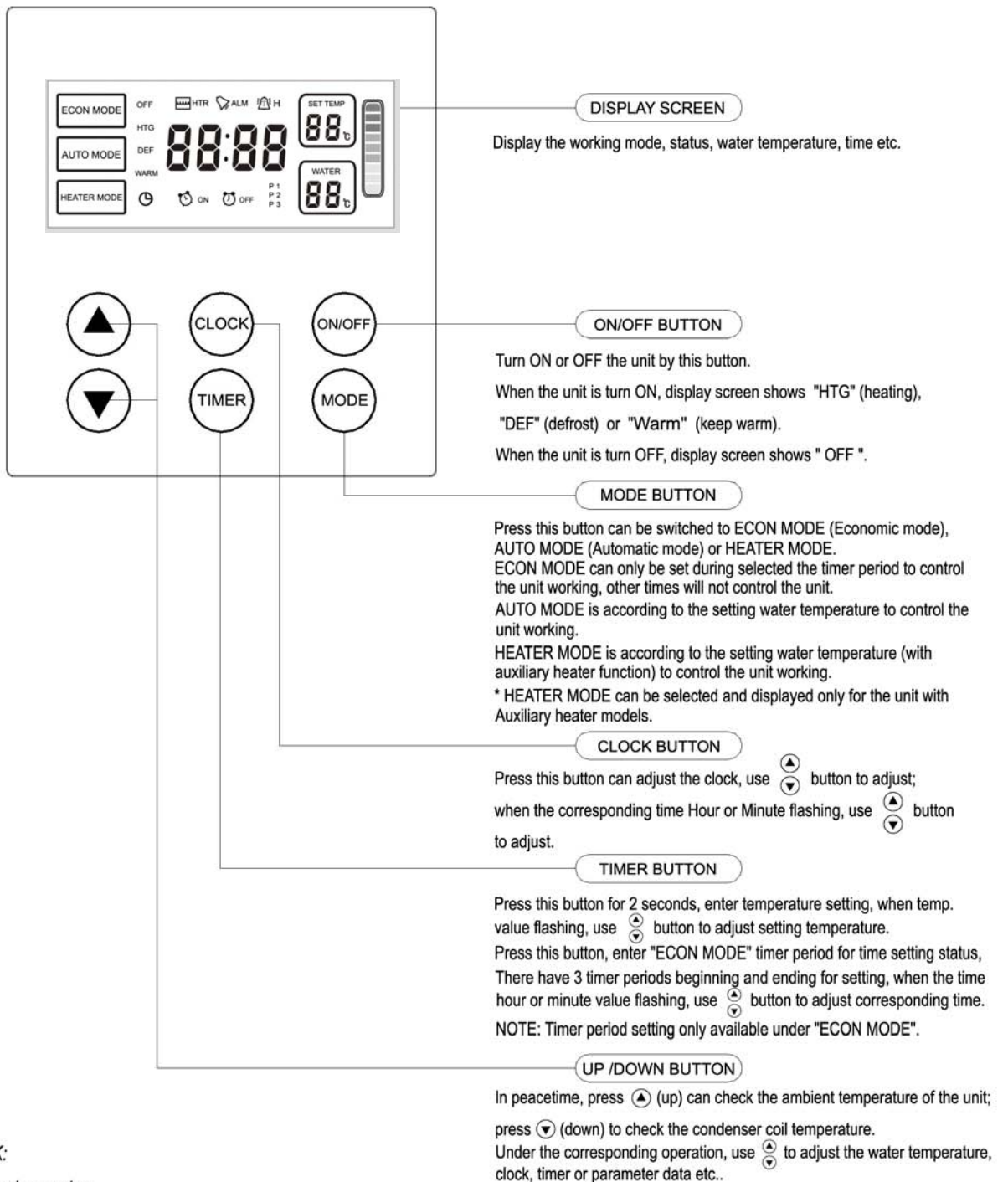

**REMARK:**

1. Set water temperature  
Press "TIMER" for over 2 seconds, enter water temp. setting status, when the setting temp. value flashing, use button to set water temp.
2. ECON MODE (Timer heating)  
There are 3 timer periods (P1, P2, P3) available for setting, they can only be set under "ECON MODE".
3. AUTO MODE  
According to the setting water temperature value to control the unit ON/OFF. Timer period setting is invalid under this mode.
4. HEATER MODE  
According to the setting water temperature value to control the unit ON/OFF (Auxiliary heater forced to operation). Timer period setting is invalid under this mode.
5. Delay protection  
When the machine restart power on, there have 3 minutes time delay protection, it's 3 minutes interval between the unit start and stop. At this time, on the screen it will display " HTG " and flashing until the unit starts operation.



D. Operation panel instruction

**2. Panel - Display:**

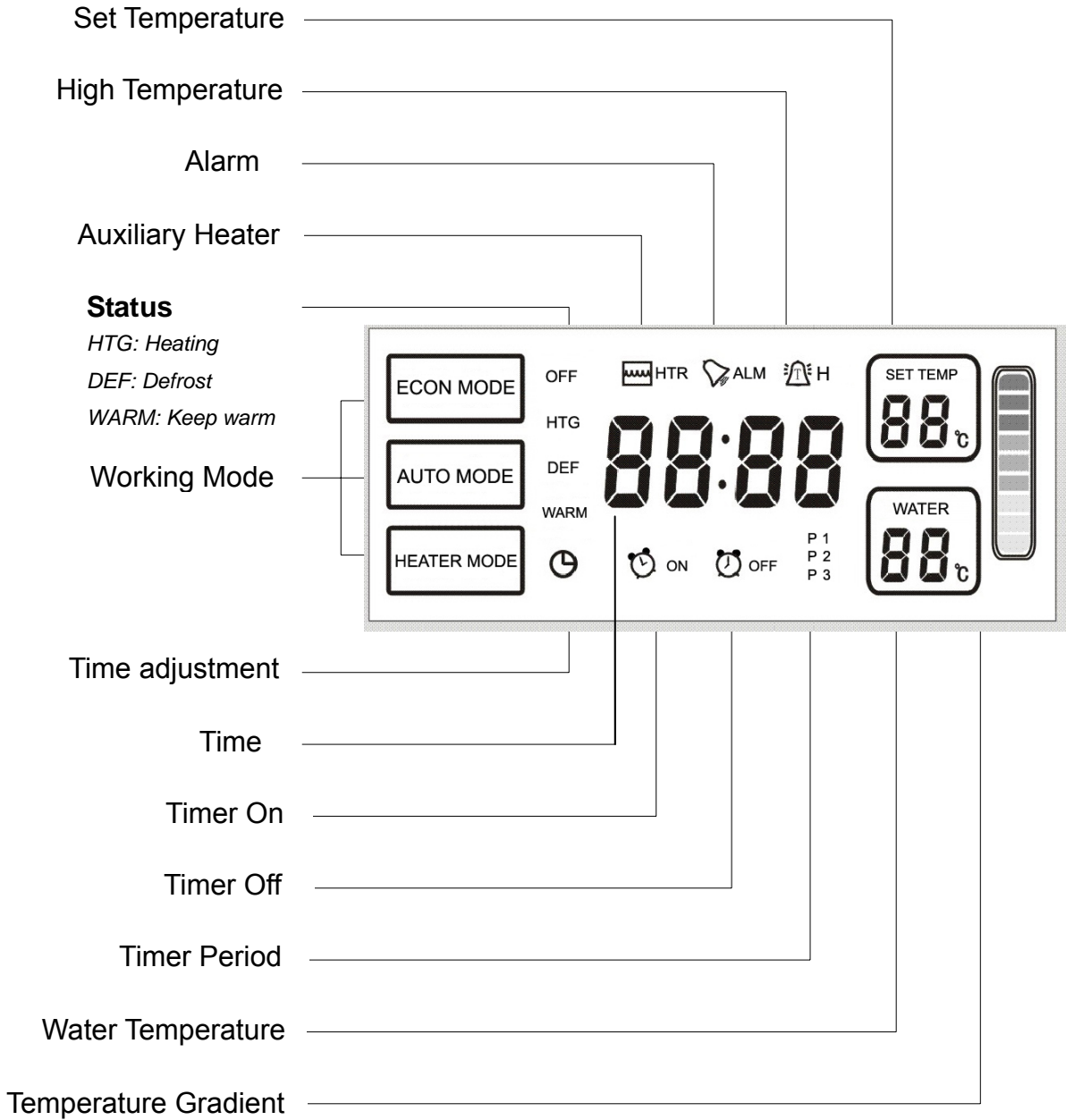

**Note:** When the water temperature exceeds 55°C, the indicator light  H on display.

## D. Operation panel instruction

### 3. Parameter Setting:

Press “MODE” button for 5 seconds; enter the Parameter setting status, the main parameter code as below sheet:

Type	Code	Parameter Name	Setting Range	Factory Setting	Unit	Remark
Temperature Control	F11	Setting temperature	5-70	55	°C	
	F12	Difference in Temp.	1 - 30	5	°C	
	F13	Determine Heat pump stop ambient temp.	-10 – 5	-7	°C	
	F14	Highest temp. for heat pump	40 – 60	55	°C	
	F15	Turn on or off electric heater mode	0 - 1	1	-	
	F16	Ambient temp. for start electric heating	-10 - 20	0	°C	
	F17	Turn on or off electric heater for sterilization function	0-1	1		
	F18	Sterilization cycle	1-990	336	hour	
	F19	Water thermal sensor temp. amendment	-5 – 5	0	°C	
Compressor	F21	Compressor start delay	0 – 10	3	minute	
Defrost	F31	Defrost start temp.	-20 – 20	-2	°C	
	F32	Defrost finish temp.	0 – 50	25	°C	
	F33	Defrost start time	1 – 999	45	minute	
	F34	Max. defrost time	Off, 1 – 99	10	minute	
Alarm	F50	Low pressure alarm mode	0 - 2	2	-	
	F51	Auto resume times of low pressure alarm	0 – 10	3	time	
	F52	Reset time of external alarm auto resume times	0 – 999	60	minute	
	F54	Electric heater overheat protection	0 - 2	2	-	
	F55	Overheat resume time	0-10	3	-	
	F56	Alarm resume time	0-999	60	°C	
	F57	Exhaust temp. protection mode	0 – 2	1	-	
	F58	Exhaust protect temp.	50 – 125	110	°C	
	F59	Exhaust temp. protection Return difference	1 – 30	10	°C	
Function Setting	F61	Memory status when power off	Yes/No	Yes	-	
	F69	Communication baud	24/48	24	-	
System Setting	F80	Password	OFF 0001 -- 9999	4321	-	“OFF” means no password. Set “0000” to clear password.
	F85	Display sterilization total time	-	-	hour	
Testing	F98	Force defrosting (refrigeration)	Control panel display “AdF”			Start compressor, 4-way valve and fan motor. Press any key to exit or 20 minutes it will exit automatic.

**Remark:** When enter Parameter setting status, press “up” or “down” to choose parameter code; after choose one, press “Timer” button to show this code’s setting value, and press “up” or “down” can set the value; After finish setting, press “Timer” button to confirm and return to Parameter code status.

## D. Operation panel instruction

### 4. Error Handling:

ERROR CODE	ERROR STATUS	REASONS	ERROR HANDLING
A1	Thermal sensor alarm	Water temp. sensor open circuit or short circuit.	1. Check the water temp. sensor connection. 2. Change the water temp. sensor.
A2	Condenser coil sensor alarm	Condenser coil temp. sensor open circuit or short circuit.	1. Check the condenser coil temp. sensor connection. 2. Change the coil sensor.
A3	Exhaust sensor alarm	Exhaust temp. sensor open circuit or short circuit.	1. Check the exhaust temp. sensor connection. 2. Change the exhaust temp. sensor.
A4	Ambient temp. sensor alarm	Ambient temp. sensor open circuit or short circuit.	1. Check the Ambient temp. sensor connection. 2. Change the ambient temp. sensor.
A5	Low /High pressure alarm	1.1. High pressure protection switch off. 1.2. Ambient temp. too high or water heat exchanger dirty block. 2.1. Low pressure protection switch off. 2.2. Leakage of refrigerant.	1.1 Check or change the high pressure protector. 1.2. Check if the surround temp. is too high, or clean the heat exchanger of water tank. 2.1. Check or change the low pressure protector. 2.2. Supply refrigerant and check if there is any leakage.
A6	(Auxiliary) electric heater protection overheat alarm	1. Electric heater protection switch off. 2. Tank water temp. too high.	1. Check if the water temp. is as LCD display, or if water temp. is too high. 2. Change the Electric heater.
A7	Exhaust temperature too high	1. Lack of refrigerant. 2. Mix with air in system. 3. Lack of lubricating oil.	1. Supply refrigerant. 2. Re-vacuumizing, and fill in refrigerant. 3. Change the lubricating oil of compressor.
--	Screen no display or display insufficiency	1. No plug in power. 2. Mainboard and operation panel communication break off.	1. Check the power line and voltage. 2. Reconnect the line of mainboard and operation panel. 3. Change the mainboard or operation panel.

#### NOTE:

1. When the unit has error, the buzzer of the operation panel will make an alarm sound, and there will show "Alarm" on the screen panel.
2. "ERROR CODE" will show on temperature display location by alternately.
3. Part of the error alarm can be automatically restored (resumed). That is the appeared alarm can be eliminated by electronically controlled self-test.
4. Some of the error alarm is caused by large fluctuation of the external power, by this, just power off and restart the unit to clear the error.
5. When the machine has error alarm and restart still can not eliminated error, please contact the after service as soon as possible for solution.

## E. Maintenance and service

---

### Examination before trial run

1. Check the water tank is filled with water, and open the water outlet tap till water flow out.
2. Check the water pressure is normal (0.15Mpa~0.7Mpa).
3. Check the air inlet or outlet is well connected; and the air outlet pipe heat insulation is completed.
4. Check the power supply voltage is normal, whether according with the nameplate requirement. (Range  $\pm 10\%$ ).
5. Check whether the equipped parts are screwed /locked well.
6. Check whether the wirings are according with the Circuit diagram, and the earth-wire is connected.
7. Check whether the wind inlet and outlet has been cleaned up and no obstacle.
8. Check whether the condensate drain pipe is connected well and no blockage.
9. After power-ON, check the control panel display is normal.

### Trial running

1. After the machine starts, to hear and determine whether there is abnormal sound or collision during operation, if there is abnormal sound, stop the unit immediately and check for it until there is no abnormal sound to continue operation.
2. For the first time power on, the compressor will have 3 minutes delay protection function.
3. Observe whether the drainage of condensate water is smooth, prevent the chassis stagnant or spill water.
4. For the first time discharge hot water or start the units after a long time closure, the water tap of outlet pipe may flow muddy water, this is a normal phenomenon, and continue to drain for a period of time can be cleared.
5. After stop operation for a long time, there may have condensation water hereabout the air outlet or pipe (especial in humidity weather), this is a normal phenomenon, use a dry washcloth to clean it or by air dry.
6. The advance setting parameters of the operation panel has been set at the factory, users no need to reset it, the maintenance person should be carefully set if needed.

### Maintenance and service

1. After carry and move the unit by the first time installation, and connects the water pipes and filled the tank with water. The machine should be rest for 1-2 hours before start trial running.
2. The water heater inlet filter needs to be cleaned once per 3 months. At the same time, we suggest draining all the storage water and repeatedly wash for 2-3 times to remove the dirt and sediment.
3. To clean the fin heat exchanger, use a hard nylon brush to clean it or the dustproof filter-net. Be careful not to damage the copper tube. If there has compressed air, use a high pressure air tube to clean the fin heat exchanger. This need to be done once per 2-3 months.
4. When clean the water tank or heat exchanger must turn off the machine and power supply.
5. If the supply cord is damaged, it must be replaced by the manufacturer or its service agent or a similarly qualified person.

## E. Maintenance and service

---

### Heat Pump main unit disassembly

If want to check and maintain the top main parts of the unit, should disassembly the cover of the unit, follow the below steps (Fig.5, 6) to process.

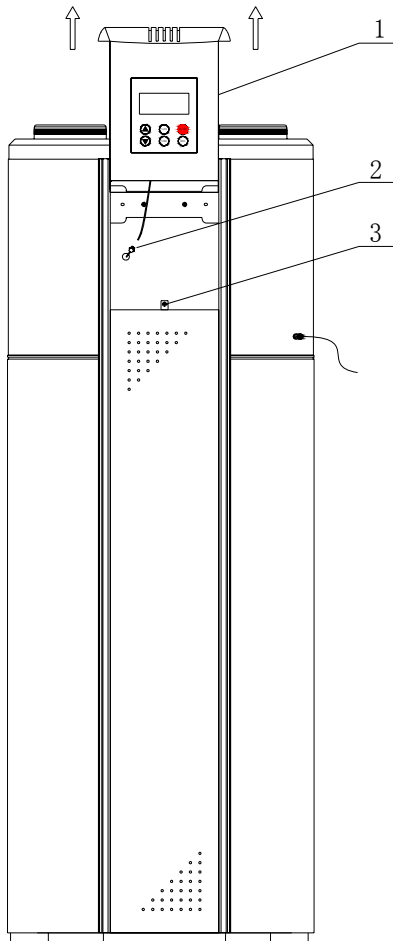

(Fig.5)

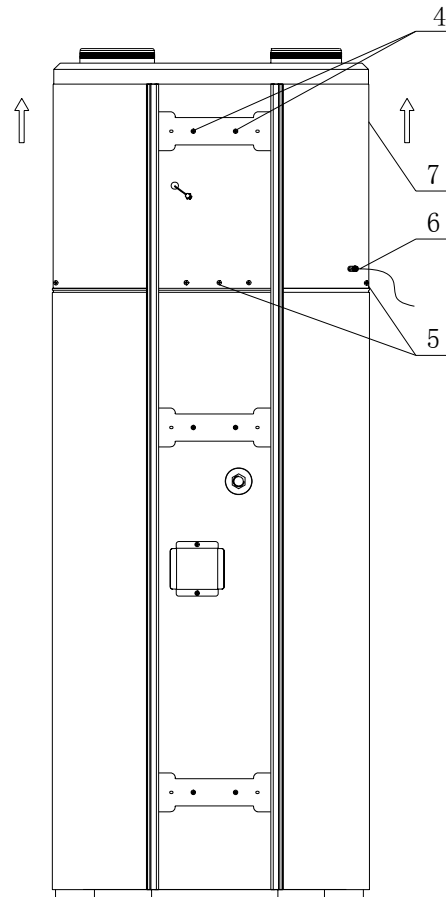

(Fig.6)

1. Move up the Control panel along the slot until exposed control panel terminal docking connector.
2. Loosen the cable terminal docking, may be continue to move up the control panel completely.
3. Unfasten the decorative plate screw, pull out a small angle (about  $10^\circ$ ), then move up to take the whole decorative plate out.
4. Take down the top section of a decorative fixed plate by loosen the screws.
5. Loosen the bottom screws of the top cover.
6. Release the power line from the top cover of fixed terminal, to prevent the power line stuck when move up the top cover.
7. Finally, remove the block objects (e.g. air ducts etc.) from the air inlet /outlet, holding both sides of the top cover and move it up.

## F. Unit circuit diagram

The following is a unit circuit diagram (for user's reference); the unit practical connection should be as the circuit /wiring diagram on the machine.

### 1). Heat pump without auxiliary electric heater:

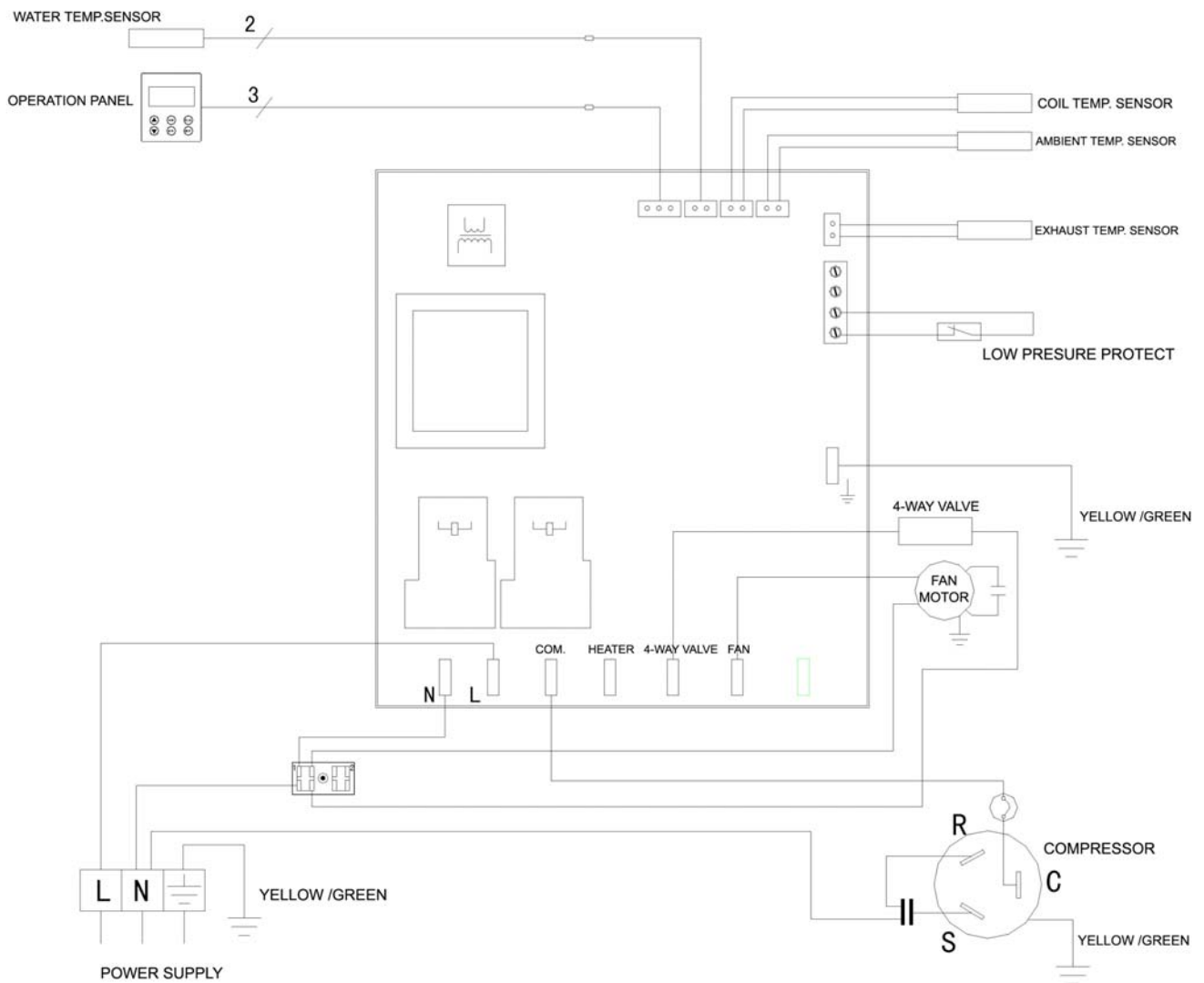

## F. Unit circuit diagram

### 2). Heat pump WITH auxiliary electric heater:

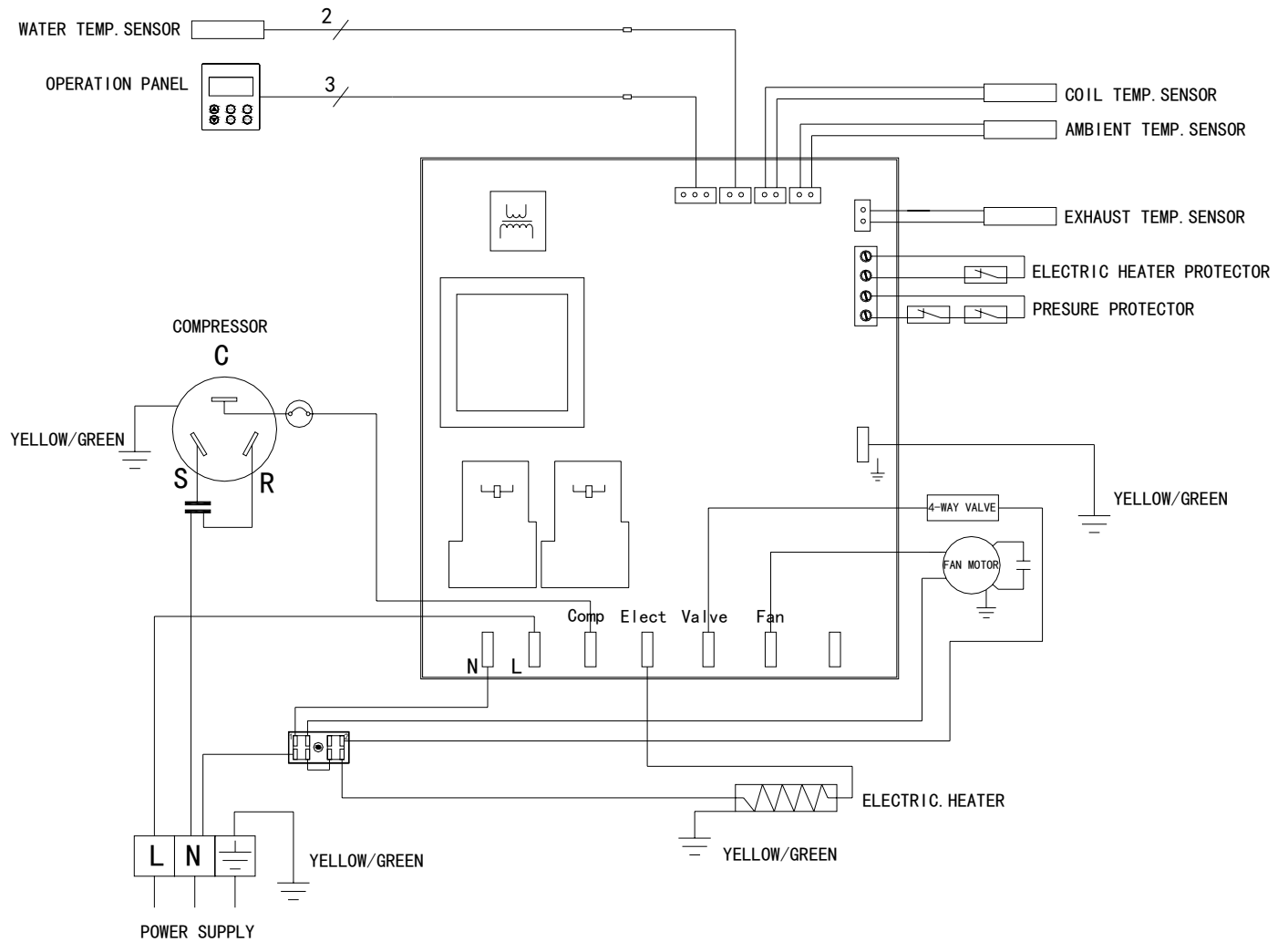

G. Annex list

---

ITEM	NAME	SPECIFICATION	QUANTITY	REMARK
1	Safety valve		1	
2	Manual		1	



